

DESIGN GUIDE



Elmira Model



Heritage Model



Cambrian Model

Table of Contents

Introduction	3
Planning for a Cambridge Elevating Home Elevator	3
Provisions by Others	4
Description of Elevator Equipment	5
Hoistway Construction – General Notes	6
Hoistway Construction – Wood Stud Wall	7
Hoistway Elevation – Overhead Requirements	8
Pit Details	9
Machine Room Details – General Layout	10
Machine Room Details – Controller / Pump Details	11
Elmira Model Cab / Hoistway Size Layout	12
Heritage Model Cab / Hoistway Size Layout	14
Cambrian Model Cab / Hoistway Size Layout	15
Cambrian Landing Frame Details - Elevation	16
Cambrian Landing Frame Details - Planview	17
Elevator Specifications for ASME A17.1 Part V Compliance	18

Introduction

This design guide assists architects, builders, contractors, home owners and elevator professionals in planning for a home elevator installation that meets the requirements of ASME A17.1 Part V/CSA B44.0.

Please note this guide provides nominal dimensions and specifications and is useful for initial planning. Before starting construction please consult the specific application drawings provided by Cambridge Elevating that indicate exact dimensions for your project.

Please note that due to product enhancements and continually evolving codes, the information in this guide is subject to change without notice.

Planning for a Cambridge Elevating Home Elevator

The following planning procedure is strongly recommended:

1. Determine the customer's intention for use.
2. Determine the customer's desired convenience level with respect to model type:
 - Elmira – swing landing door with manual (or automatic) accordion cab gate
 - Heritage – swing landing door with automatic sliding cab door panels
 - Cambrian – automatic sliding door panels on cab and each landing
3. Determine local, state and national code requirements of site.
4. Use pages 6 through 9 for hoistway construction, pit depth and overhead clearance requirements.
5. Use pages 10 and 11 to plan for a machine room and electrical requirements.
6. Use page 12 through 15 to determine car and hoistway size requirements.
7. Use page 15 and 16 to plan for the Cambrian model's sliding landing frames.

Provisions By Others

- Provide one permanent 220/1/60 (30 amps) & one 110/1/60 (15 amps) power supply with disconnect to hydraulic power unit, at a location not greater than 20 feet from the elevator hoistway. (220V disconnect provided by elevator manufacturer. Ontario jobs receive both 120V & 220V disconnects).
- Provide appropriate sleeves for both the electrical conduit and hydraulic line from the drive unit to the hoistway. Trenching may be required if the machine room is not adjacent to hoistway.
- Provide an enclosed, plumb and square hoistway with smooth interior surfaces, as per elevator manufacturer's engineered drawings. Include for fascias or furring of hoistway interior. To be inspected and confirmed by elevator contractor prior to elevator installation.
- Provide required overhead clearance based on engineered drawings.
- Provide floor finishes inside elevator cab.
- Suitable lintels over landing entrances are to be provided for Cambrian model only – per Cambrian Landing Frame Details, see page 16-17.
- Provide required rough openings at each hoistway landing as per elevator manufacturer's engineered drawings.
- Provide sufficient machine-room area suitable to contain hydraulic power unit and elevator controller & disconnect based on elevator manufacturer's engineered drawings.
- Provide telephone connection to outside line for integration into elevator controller.
- Provide required pit depth and size as per elevator manufacturer's engineered drawings.
- Provide substantial level pit floor slab to support loads indicated on elevator manufacturer's engineered drawings.
- Provide required structural support for guide rail fastenings as per elevator manufacturer's engineered drawings.
- Install rail bracket inserts (Supplied by CE) into concrete rail support wall during construction per elevator manufacturer's engineered drawings, only if required.
- Provide required building permit(s) and/or engineering services as per local authorities.
- Provide pit water proofing or sump pump, only if required.
- Provide all finishes around landing door frames and landing entrances.

Description of Elevator Equipment

General

- Rated load: 950 lb.
- Nominal speed: 40 feet per minute
- *Elmira* minimum pit depth: 8"
- *Elmira* minimum overhead clearance: 96"
- *Heritage/Cambrian* minimum pit depth: 12"
- *Heritage/Cambrian* minimum overhead: 108"
- Maximum travel: 50 feet
- Maximum number of stops: 6

Mechanical Equipment

- 208/230 VAC, 60 Hz, 30 Amp single phase power
- Dual 8 lb. modular T-rail system
- Two 3/8" diameter, 17 x 9 wire ropes
- Sling assembly
- Forged rope sockets
- 2:1 roped hydraulic single stage cylinder
- 4.0 hp submersed motor with 2-speed adjustable valve system

Cab and Appointments

- Car size: Up to 15 sq. ft.
- Cab height: *Elmira* - 82", *Heritage/Cambrian* - 86"
- Two (2) recessed cab lights for *Elmira*
- Four (4) recessed cab lights for *Heritage/Cambrian*
- Interior cab walls and ceiling finish, choice of:
Melamine - white, oak, maple, walnut, autumn glow
Veneer (unfinished) – oak, maple, birch, cherry
Medium density fibreboard (MDF)
Rough plywood, finished by others
- Rough plywood cab floor with 3/4" recess

Gates and Doors

- *Elmira*
Swing door for each landing
Horizontally collapsible accordion style car gate
- *Heritage*
Swing door for each landing
Automatic sliding cab door panels in beige epoxy
- *Cambrian*
Automatic sliding cab door panels in beige epoxy
Automatic sliding landing door panels in beige epoxy

Controls

- Microprocessor controller with relays for basic operation
- Fully automatic operation
- Automatic timed cab lighting
- Stainless steel car operating panel (COP), telephone box and hall call stations
- Dual illuminated hall call station push buttons and position indicating push buttons on COP
- Emergency stop switch on COP
- LED/dot matrix Digital Position Indicator (DPI) in car and at each landing (*Heritage/Cambrian*)

Safety Devices

- Stainless steel handrail inside cab
- 208/230 VAC lockable disconnect for power unit
- Final limit
- Slack rope safety switch
- Pit stop switch
- Car top stop switch
- Line rupture valve
- Low pressure switch
- Automatic releveling
- Emergency battery lowering
- Electro-mechanical door interlocks
- Manual lowering device
- Telephone in cab

Options

- Custom cab sizes/heights. Oversized cabs where permitted (variance may be required)
- Unfinished oak, maple or cherry solid hardwood / face frame hardwood cab walls and ceiling
- Stainless steel patterned cab walls and ceiling
- Custom finish elevator fixtures (COP, telephone box and hall call stations) in choice of finish: Brushed brass, black, oil rubbed bronze, polished stainless, brushed nickel.
- Two piece hydraulic jack
- Additional handrails in cab
- Handrail COP (all models)
- LED/dot matrix Digital Position Indicator (DPI) on landing (*Elmira*)
- Veneer and decorative metal wrapped sliding door panels (*Heritage/Cambrian*)

Hoistway Construction – General Notes

- A load-bearing wall is required to sustain rail reactions; please see *Rail Wall Construction – Wood Stud Wall (next page)* for detail.
- Hoistway must be in accordance with ASME A17.1/CSA B44.0, **AND** all local codes and regulations.
- Pit floor construction must withstand a 4000 lb. load.
- Due to limited clearances, it is necessary that hoistway walls be square and plumb. Maximum permissible deviation from hoistway top to bottom is 1/8”.
- Building structure must sustain a chain hoist for hoisting elevator materials to the top of the hoistway during installation.
- A structural engineer must ensure that building and hoistway can safely support all loads imposed by the elevator equipment.
- The drawings contained herein have been prepared using engineering principles and the design loads that are applied by the rails to the wall. However the details and member sizes and the attachments to the structure should not be construed as a complete wall system. The contractor and/or the project engineer are responsible to evaluate the other loads that are applied to the wall from the floor or roof system and modify sizes or connections as required by their analysis.

Hoistway Construction – Wood Stud Wall

3/4" PLYWOOD SCREWED TO STUDS EVERY 12" WITH #10X2-1/2" WOOD SCREWS MINIMUM

RAIL WALL
3/4" PLYWOOD

DRYWALL

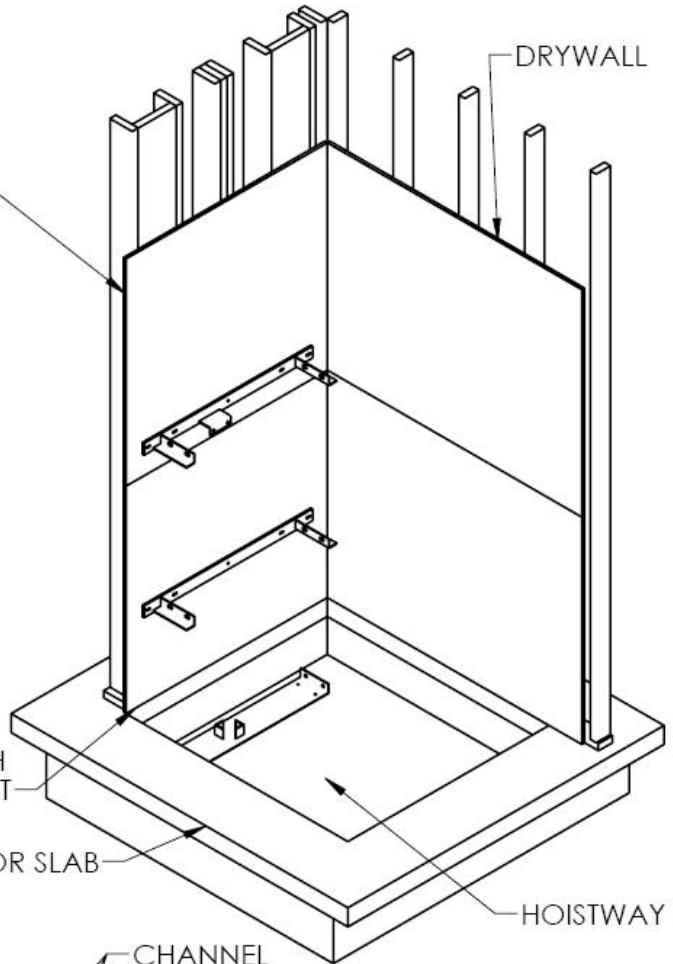

MIDDLE STUDS

FLOOR SLAB

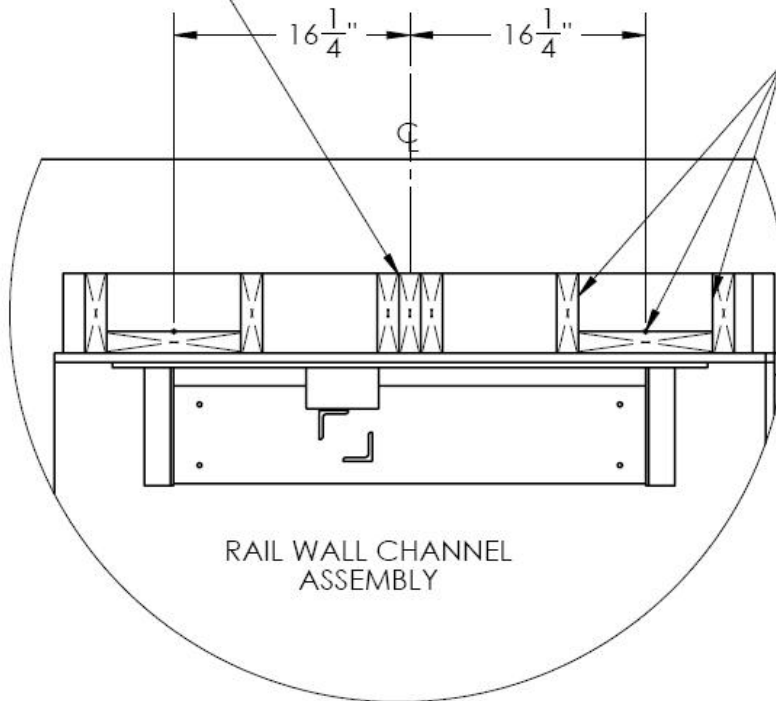

2" X 6" FULL HEIGHT QTY 2
2" X 10" FULL HEIGHT QTY 1
CHANNEL CONSTRUCTION
TYPICAL 2 PLACES
2X6 SCREWED TO 2X10 EVERY
6" WITH #10X3-1/2" WOOD
SCREWS
MIDDLE STUDS FOR CENTER
REFERENCE ONLY.
STUDS CAN BE ALTERED

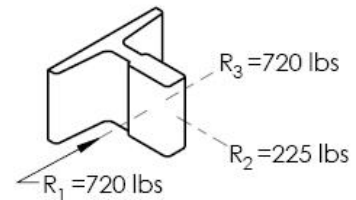

RESIDENTIAL HOISTWAY LAYOUT

CAMBRIDGE ELEVATING IS NOT RESPONSIBLE FOR THE STRUCTURAL DESIGN OF THE BUILDING AND ITS ABILITY TO SUPPORT THE ELEVATOR LOADS AND/OR REACTIONS

Hoistway Elevation – Overhead Requirements

Minimum Overhead Clearance

Elmira: 96”

Heritage / Cambrian: 108”

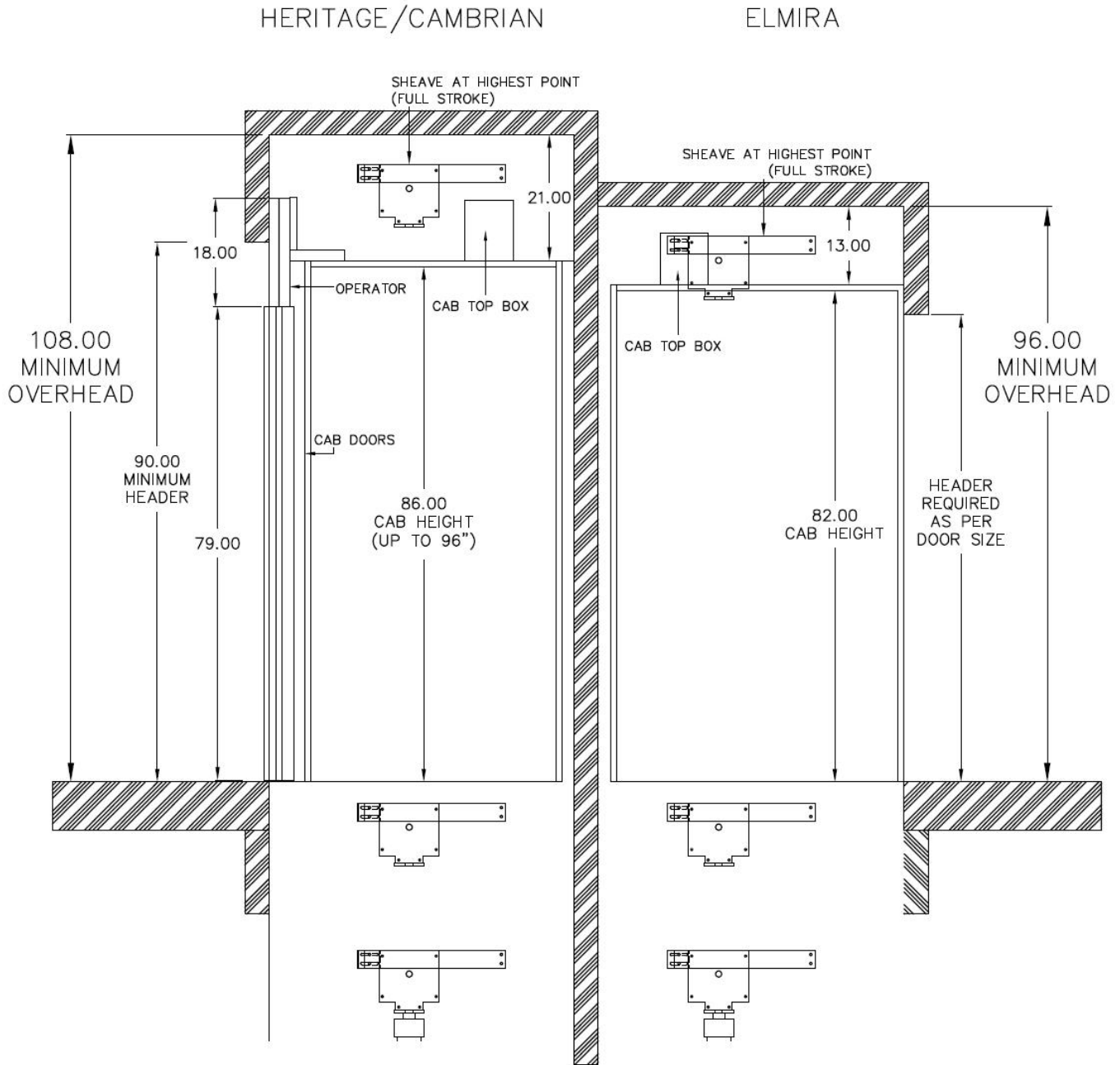

Pit Details

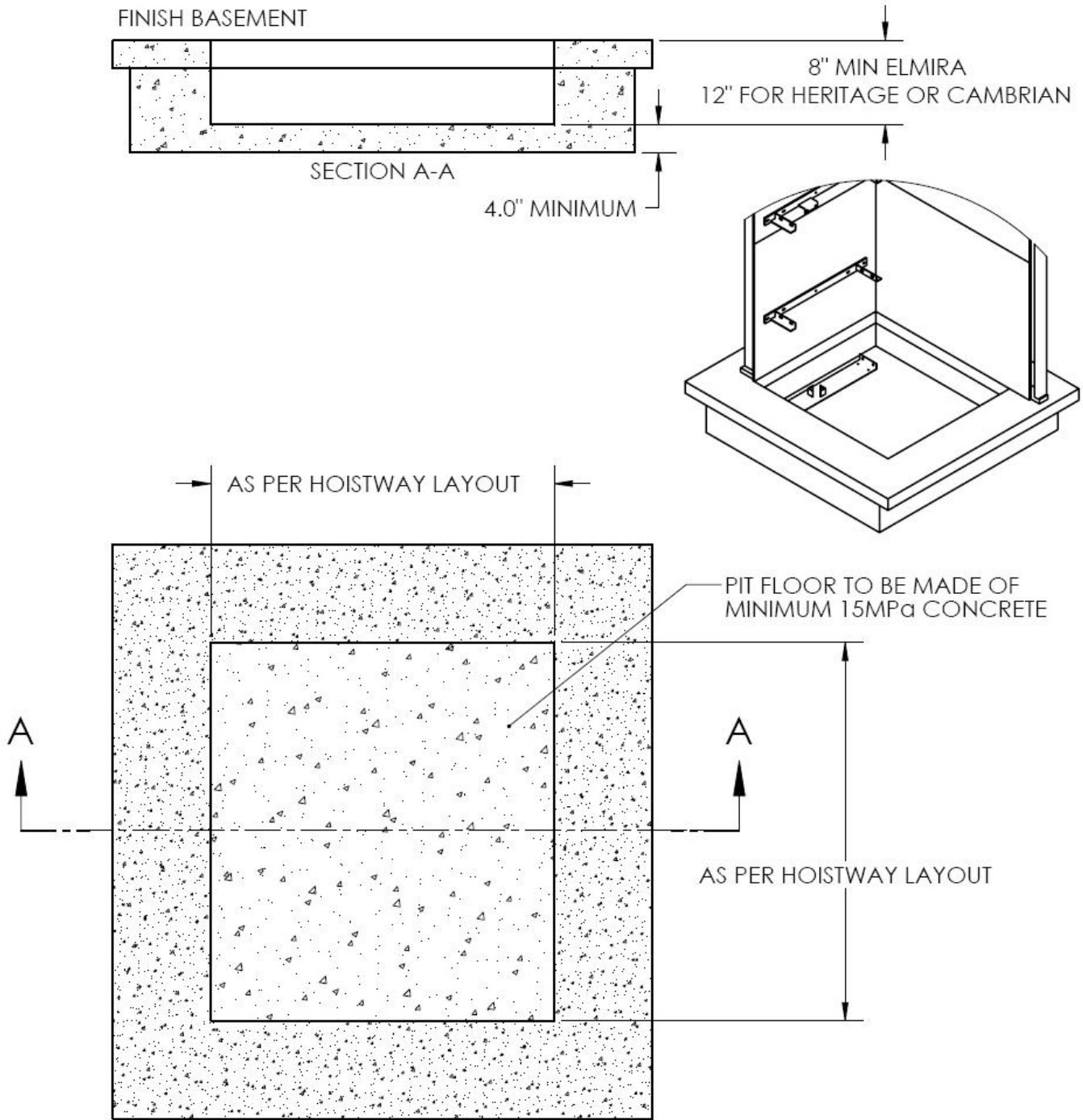

PIT FLOOR TO BE DESIGNED FOR AN IMPACT LOAD OF 9600LBS
AND A STATIC LOAD OF 5500LBS UNDER CYLINDER

REINFORCING AND STRENGTH AS PER LOCAL
STANDARDS AND CODES

Machine Room Details – General Layout

- Machine room must be in accordance with all codes and regulations.
- A 208/230 VAC, 60 Hz, 30 Amp single phase power source in the machine room to be provided.
- A 110/120 VAC, 60 Hz, 15 Amp single phase power source in the machine room to be provided.
- A telephone line circuit to be provided if required. This circuit must be connected to an outside line.

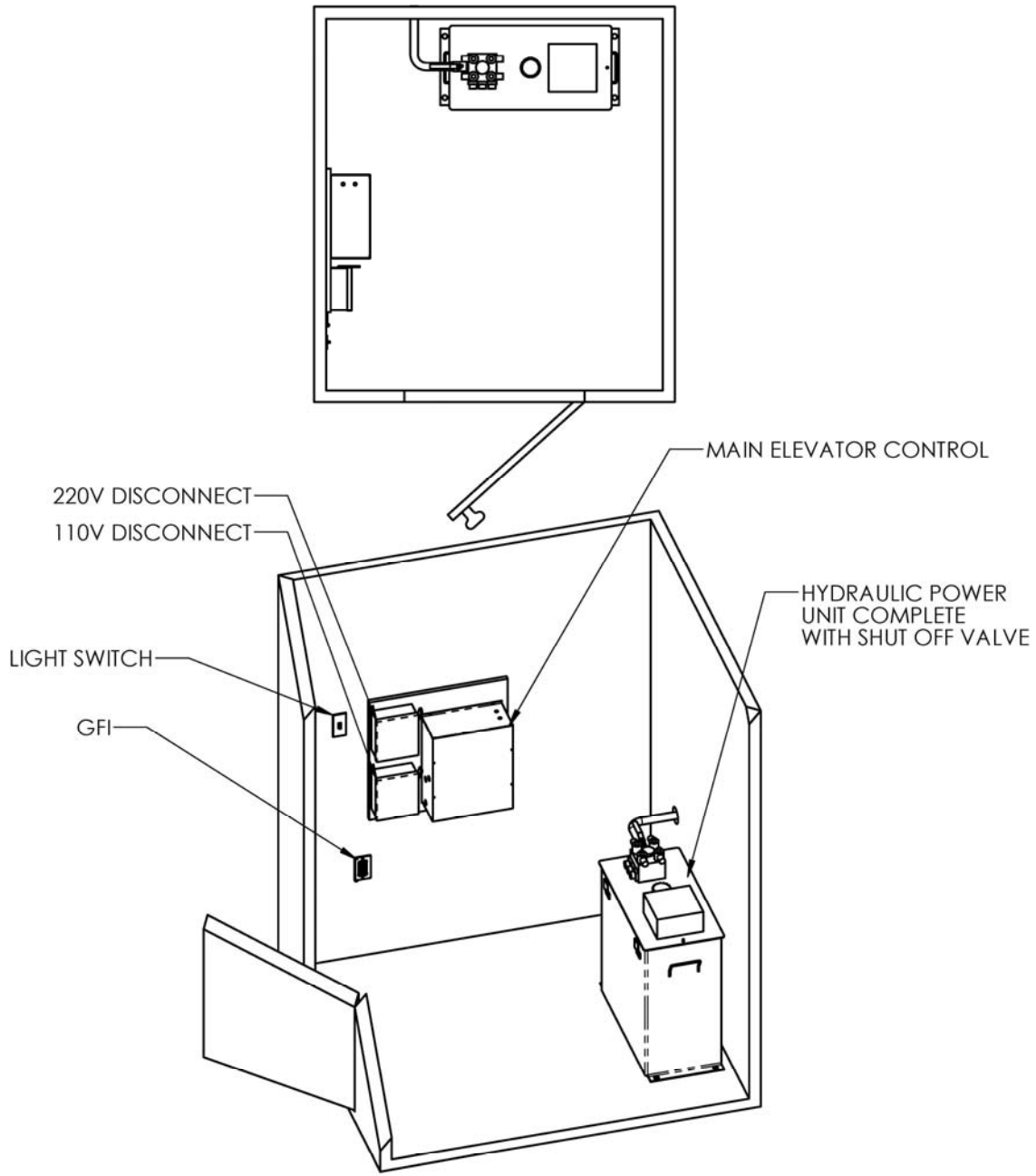

TYPICAL RESIDENTIAL MACHINE ROOM
MAY NOT BE REQUIRED

Machine Room Details – Controller / Pump Details

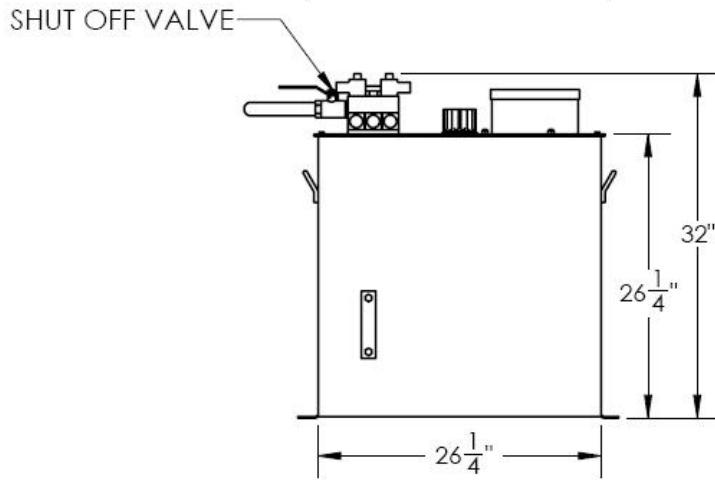
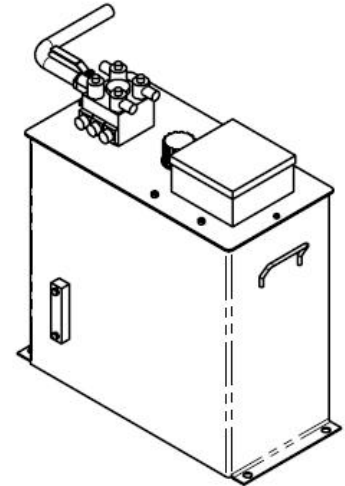
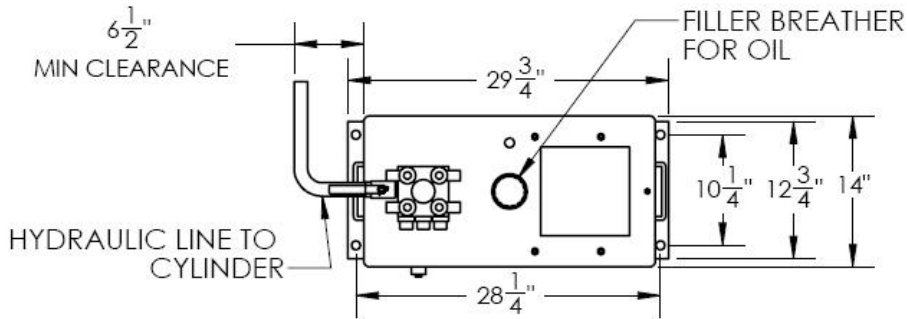

TO BE LOCATED WITHIN 20ft OF ELEVATOR SUPPORT WALL FOR LONGER DISTANCES CONSULT CAMBRIDGE ELEVATING

4.0 H.P. 220V/1/60Hz DRIVE MOTOR ACCESS REQUIRED TO TOP OF UNIT FOR OIL FILLING AND PIPING

DISCONNECT SUPPLIED BY C.E.I. ON MAIN ELEVATOR CONTROL PANEL

HYDRAULIC POWER UNIT

HYDRAULIC OIL:
32 WEIGHT PREMIUM
CAPACITY: 75L / 20 US Ga

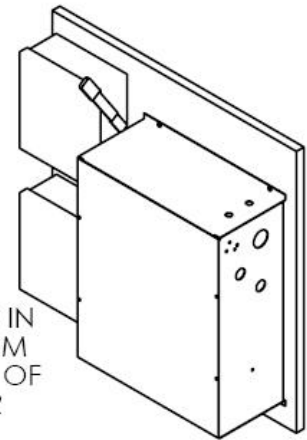
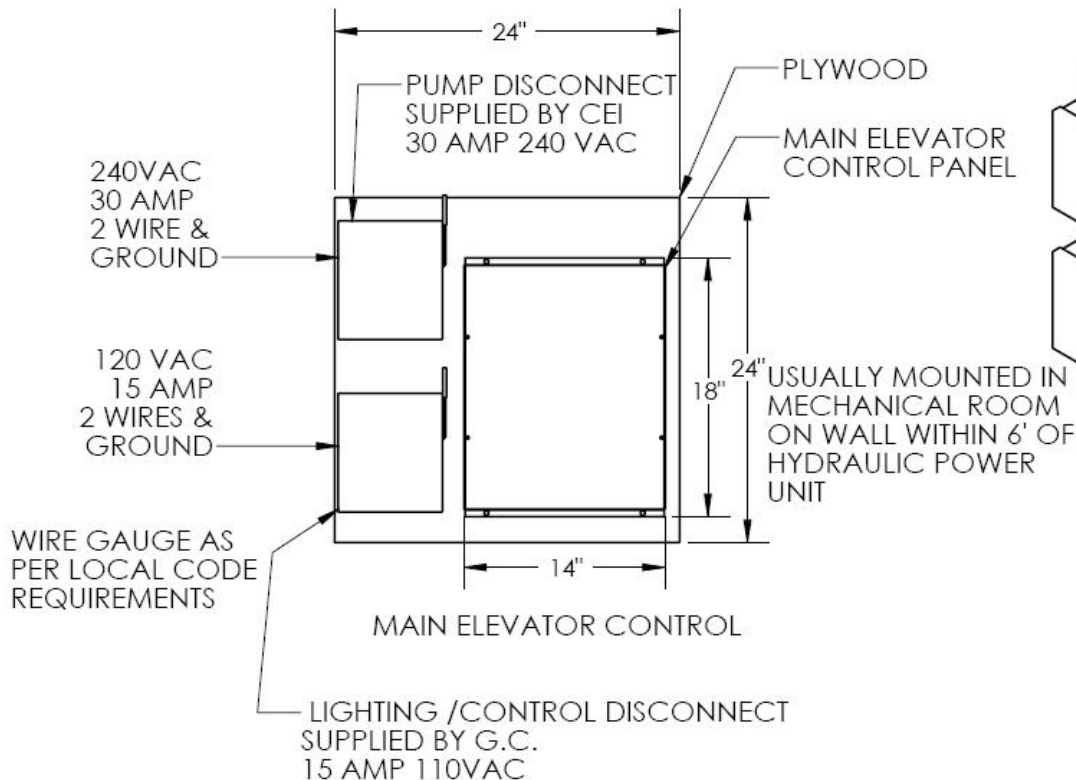

Elmira Model Cab / Hoistway Size Layout

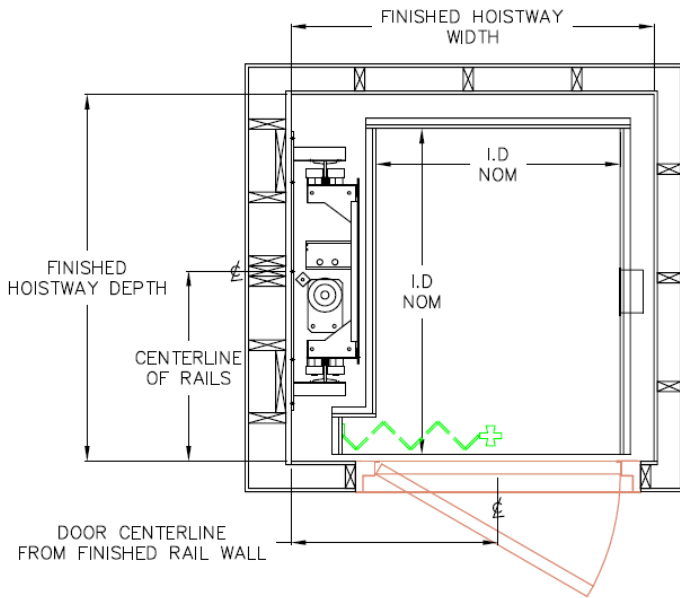

TYPE 1 – INLINE

Cab Size	Hoistway Size Width x Depth	Centerlines	
		Landing Door	Rail Wall
36" x 48"	53.5" x 54"	30.5"	28"
36" x 54"	53.5" x 60"	30.5"	29"
36" x 60"	53.5" x 66"	30.5"	32"
40" x 48"	57.5" x 54"	34.5"	28"
40" x 54"	57.5" x 60"	34.5"	29"

Please note dimensions remain for mirrored configurations.

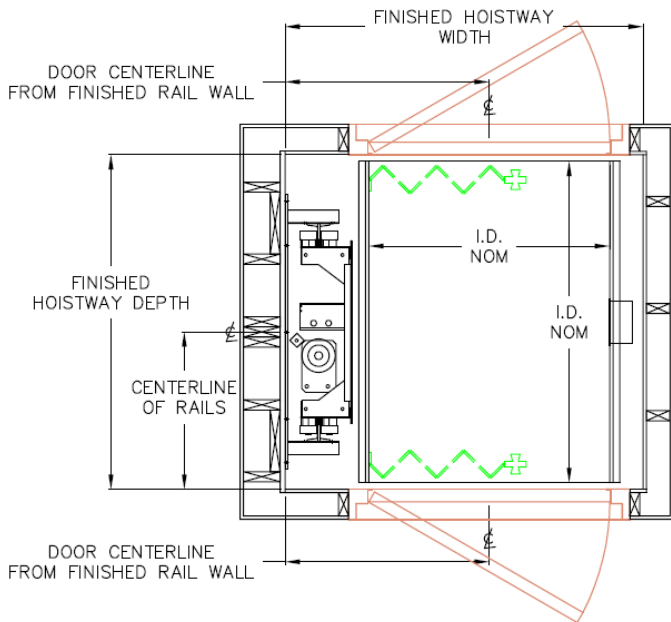

TYPE 2 – THROUGH

Cab Size	Hoistway Size Width x Depth	Centerlines	
		Landing Door	Rail Wall
36" x 48"	53.5" x 50"	30.5"	23.5"
36" x 54"	53.5" x 56"	30.5"	28.0"
36" x 60"	53.5" x 62"	30.5"	31.5"
40" x 48"	57.5" x 50"	34.5"	25.0"
40" x 54"	57.5" x 56"	34.5"	29.0"

Please note dimensions remain for mirrored configurations.

Elmira Model Cab / Hoistway Size Layout

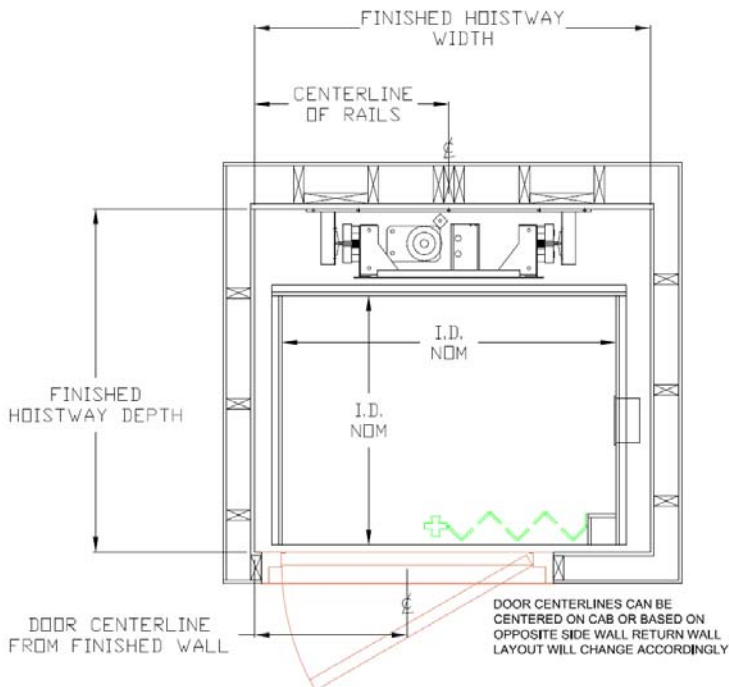

TYPE 5 – INLINE

Cab Size	Hoistway Size		Centerlines	
	Width	x Depth	Landing Door	Rail Wall
48" x 36"	57"	x 49.5"	22"	28"
48" x 44"	57"	x 57.5"	22"	28"
54" x 36"	63"	x 49.5"	22"	31"
60" x 36"	69"	x 49.5"	22"	34"

Please note dimensions remain for mirrored configurations.

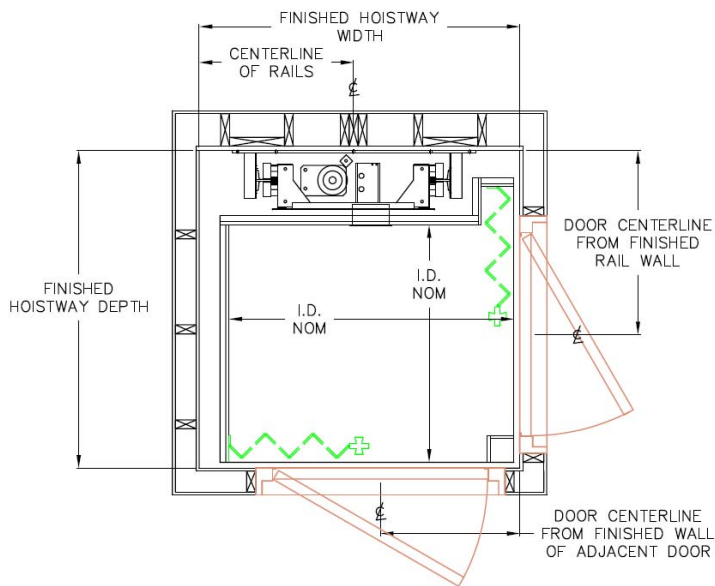

TYPE – 90 Degree

Cab Size	Hoistway Size		Centerlines	
	Width	x Depth	Landing Door	Rail Wall
Contact Cambridge Elevating (1-800-265-3579) for cab and hoistway size details. All 90 degree configurations are custom.				

Please note dimensions remain for mirrored configurations.

Heritage Model Cab / Hoistway Size Layout

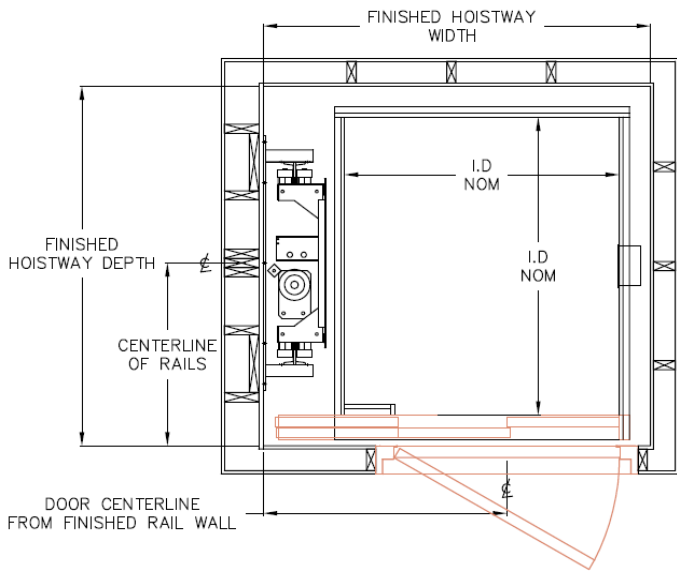

TYPE 1 – INLINE

Cab Size	Hoistway Size Width x Depth	Centerlines	
		Landing Door	Rail Wall
44" x 48" (2 panel)	62" x 58"	39"	29.5"
36" x 48" (3 panel)	58" x 59"	31.5"	28.5"
36" x 60" (3 panel)	58" x 71"	31.5"	34.5"
40" x 54" (3 panel)	60" x 65"	35.25"	31.5"

Please note dimensions remain for mirrored configurations.

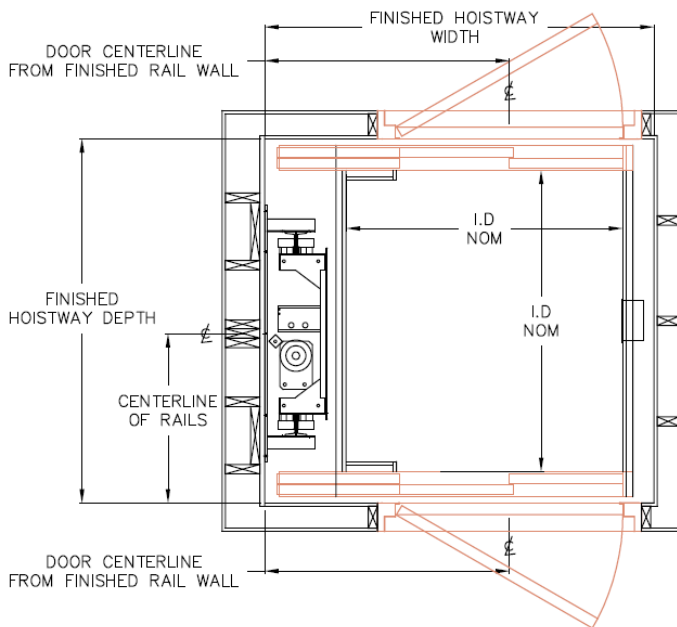

TYPE 2 – THROUGH

Cab Size	Hoistway Size Width x Depth	Centerlines	
		Landing Door	Rail Wall
44" x 48" (2 panel)	62" x 58"	39"	27"
36" x 48" (3 panel)	58" x 61.5"	31.5"	28"
36" x 60" (3 panel)	58" x 73.5"	31.5"	35"
40" x 54" (3 panel)	60" x 67.5"	35.25"	32"

Please note dimensions remain for mirrored configurations.

Cambrian Model Cab / Hoistway Size Layout

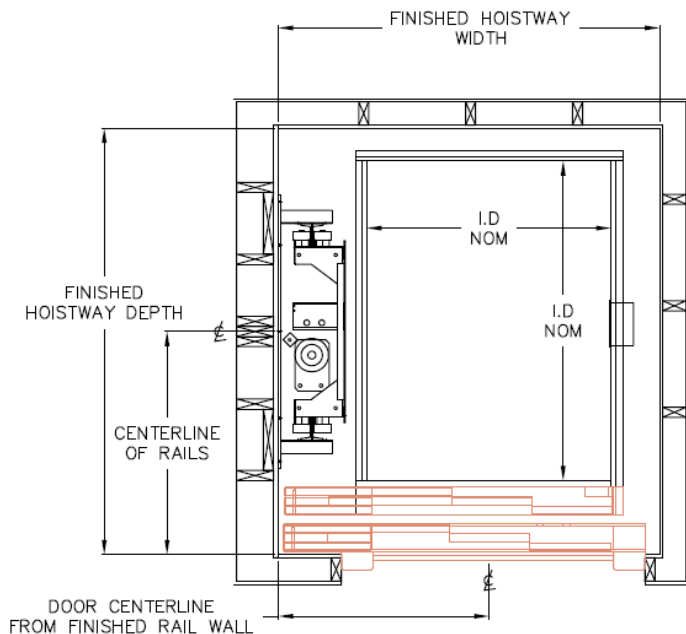

TYPE 1 – INLINE

Cab Size	Hoistway Size Width x Depth	Centerlines	
		Landing Door	Rail Wall
44" x 48" (2 panel)	64" x 62"	39"	34"
36" x 48" (3 panel)	58" x 64"	31.5"	33.5"
36" x 60" (3 panel)	58" x 76"	31.5"	39.5"
40" x 54" (3 panel)	60" x 70"	35.25"	36.5"

Please note dimensions remain for mirrored configurations.

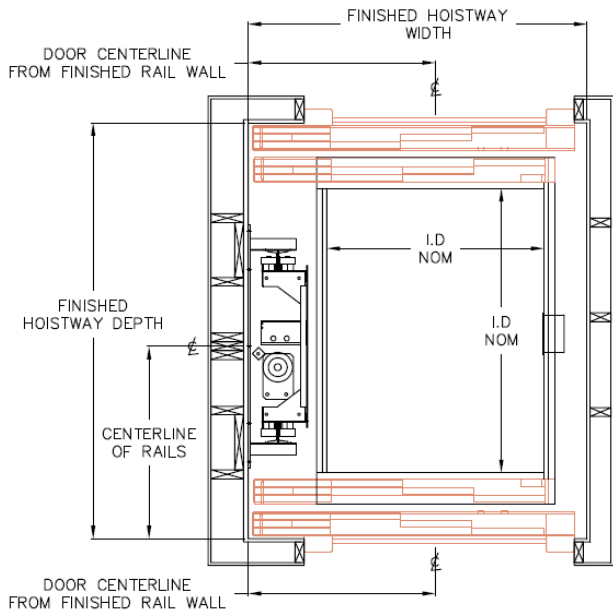

TYPE 2 – THROUGH

Cab Size	Hoistway Size Width x Depth	Centerlines	
		Landing Door	Rail Wall
44" x 48" (2 panel)	64" x 66.5"	39"	33"
36" x 48" (3 panel)	58" x 70.25"	31.5"	32.5"
36" x 60" (3 panel)	58" x 82.25"	31.5"	41"
40" x 54" (3 panel)	60" x 76.25"	35.25"	36.5"

Please note dimensions remain for mirrored configurations.

Cambrian Landing Frame Details – Elevation

- It is the recommendation of Cambridge Elevating to leave door walls wide open for installation.
- Landing door jambs and header fit within rough stud opening. Landing door operating mechanism, door frames and sill hang in hoistway attached to inside wall of hoistway using brackets.
- Drawing below depicts view from landing looking into elevator hoistway (rails support on right wall).

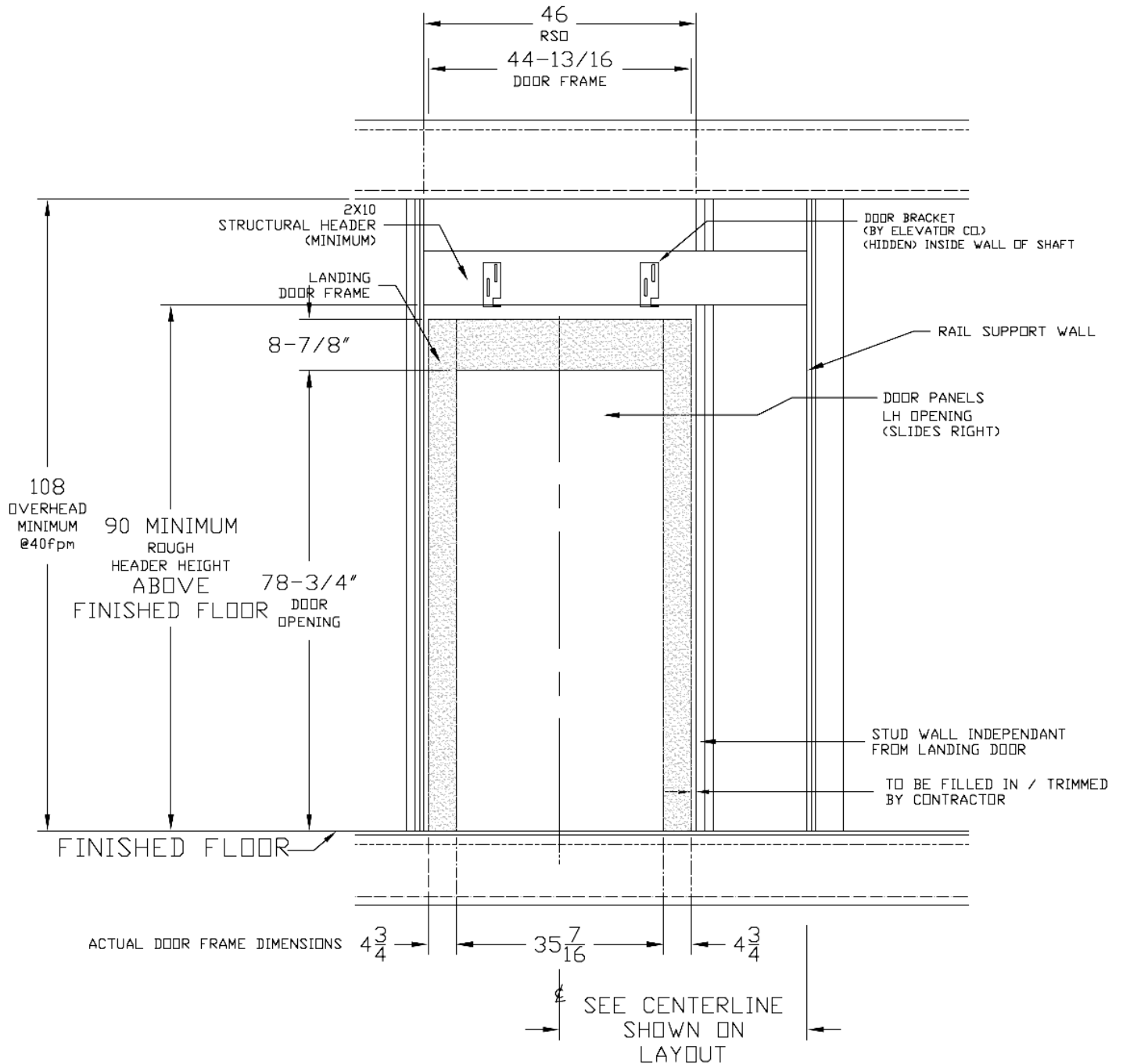

Cambrian Landing Frame Details – Planview

- It is the recommendation of Cambridge Elevating to leave door walls wide open for installation.

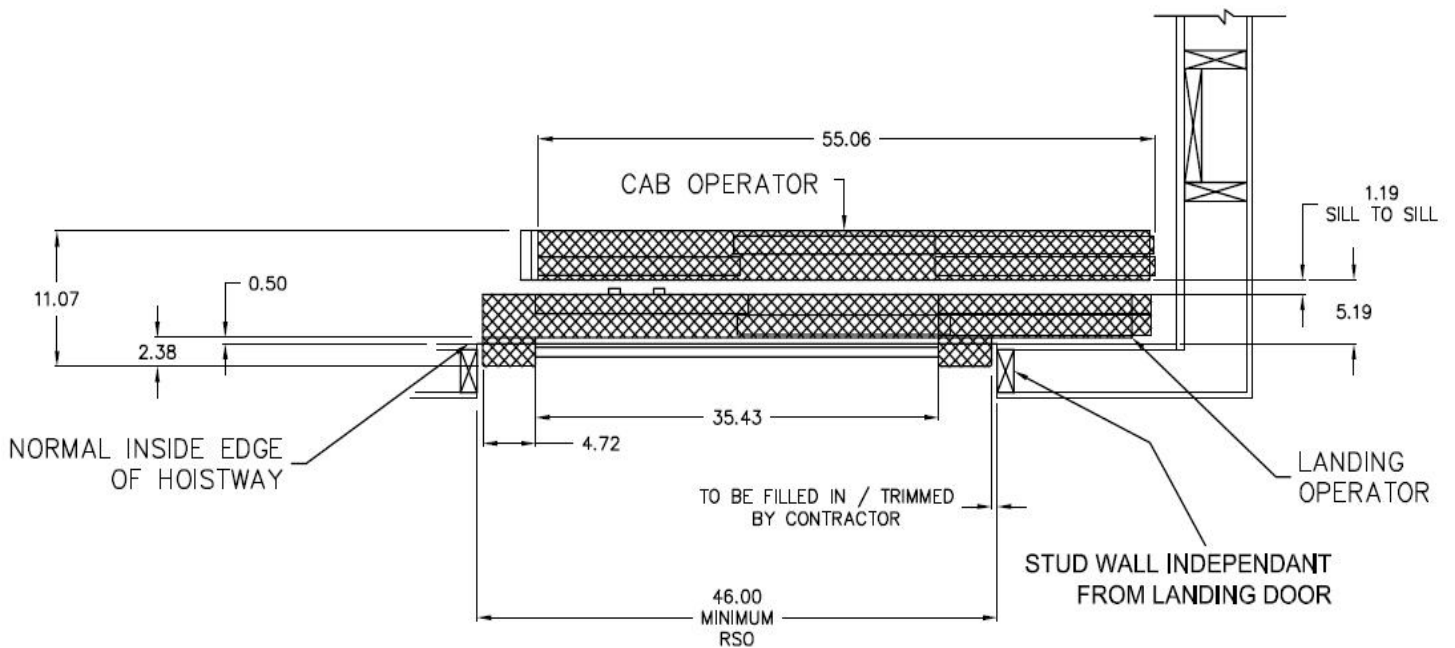
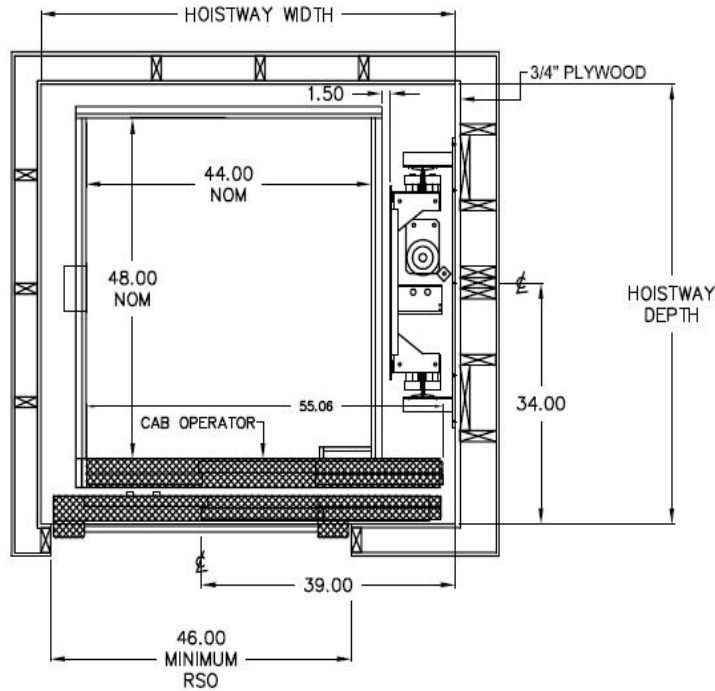

Cambridge Elevating Inc. Residential Elevator Specifications

PART 1 – GENERAL

1.1 Summary

This specification describes the planning, labor, and materials required to install a private residence home elevator manufactured by Cambridge Elevating Inc.

1.2 System Description

A private residence 1:2 roped hydraulic elevator complete with guide rail system, hydraulic power unit, control panel, switches, wiring and any parts necessary to properly install the elevator to meet performance, safety and code standards.

1.3 Quality Assurance

The elevator shall be designed, tested and installed in compliance with all applicable regulations and in accordance with ASME A17.1/CSA B44.0 standards. Elevator may be subject to state, local and city approval prior to installation and subject to inspection after installation.

1.4 Applicable Codes and Standards

- 1.4.1 ASME A17.1/CSA B44.0, Section 5.3 *Private Residence Elevators*
- 1.4.2 ASME A17.5/CSA B44.1, *Elevator and Escalator Electrical Equipment*
- 1.4.3 ICC/ANSI A117.1-1998, *Accessible and Usable Buildings and Facilities*
- 1.4.4 NFPA 70-1999, *National Electric Code*
- 1.4.5 ADAAG, *Americans with Disabilities Act Accessibility Guidelines*

PART 2 – PREPARATORY WORK BY OTHERS

2.1 Hoistway

Provide an enclosed, plumb and square hoistway with smooth interior surfaces. Provide fascias or furring of hoistway interior where required. Provide correct door RSO and headers as described on site specific layout drawings. Construction of hoistway, including rail support wall and pit floor must withstand all loads as described on site specific layout drawings. Rail wall construction must provide adequate anchoring means for guide rail support system as described in hoistway detail drawings.

2.2 Machine Room

Provide a machine room as required by applicable codes and standards.

2.3 Electrical

2.3.1 General Contractor to provide one 208/230 VAC, 60 Hz, 30 Amp single phase power source in the machine room. 230 VAC disconnect provided by CEI.

2.3.2 General Contractor to provide one 120VAC, 60 Hz, 15 Amp power source and disconnect in the machine room. 120 VAC disconnect provided by CEI for Ontario installations.

PART 3 – SUBMITALS

3.1 Approval Drawings

Approval drawings shall show a complete layout of elevator equipment, including plan and elevation views.

PART 4 – PRODUCT

4.1 Equipment Manufacturer

The elevator shall be manufactured by Cambridge Elevating Inc.

4.2 Components

The elevator will have the following components.

4.2.1 Cab

4.2.1.1 Car size

<i>Elmira Model</i>	<i>Heritage and Cambrian Models</i>
36" x 48" x 82"	44" x 48" x 86"
36" x 54" x 82"	36" x 48" x 86" (Optional with 3 spd/panel system)
36" x 60" x 82"	36" x 54" x 86" (Optional with 3 spd/panel system)
40" x 54" x 82"	36" x 60" x 86" (Optional with 3 spd/panel system)
44" x 48" x 82"	40" x 54" x 86" (Optional with 3 spd/panel system)

Custom cab sizes up to 48" x 60". Please consult our engineering department.

4.2.1.2 Cab Configuration

Inline (enter/exit same side), 90 degree or straight-thru layouts available.

4.2.1.3 Cab Construction

Metal bracket and/or tubular frame structure with melamine, veneer, stainless steel or laminate finish panels. Ceiling white melamine or to match walls. Rough plywood floor; finish flooring by General/Elevator Contractor.

4.2.1.4 Car Operating Panel

Flush panel built into cab wall with brushed stainless steel. Floor selection pushbuttons complete with dual color LED floor number and annular ring. Alarm button, emergency stop button, emergency light and integral phone box with phone and hinged cover.

4.2.1.5 Hand Rail

Brushed stainless steel handrail mounted to cab wall (shipped loose in unfinished cabs) in solid flat bar or cylindrical.

4.2.2 Hydraulic Power Unit and Motor

Power unit to consist of 20 gallon enclosed metal tank, 4.0hp or 5.0hp submersible induction motor and pump. Two speed valve complete with adjustable levelling, pressure relief valve and shut off ball valve. Pressure gauge, manual lowering valve and overheat thermistor included. Tank heater option available.

4.2.3 Controller

Certified relay controller utilizing Machine Control Unit (MCU) to manage the flow of signal information. Battery back-up to allow lowering of car and unlocking and opening of doors.

4.2.4 Cylinder

Single stage jack with line rupture valve, 750 psi working pressure.

4.2.5 Ropes

Two 3/8" diameter, 9 x 17 wire ropes.

4.2.6 Guide rail

Dual 8 lb. steel modular T-rail system.

4.2.7 Car Sling

The elevator cab shall be supported by the car sling. The car sling shall be made of structural and formed steel and equipped with guide rollers and Type A roller safeties complete with slack rope safety switch.

4.2.8 Gates and Doors

Landings: Automatic horizontally sliding two or three speed side opening beige epoxy or brushed stainless door panels complete with matching frame and sill. OR Manual swing door on landing provided by General Contractor. Door interlock provided by CEI (Automatic door operator available).

Cab Door/Gate: Automatic horizontally sliding two or three speed side opening beige epoxy or brushed stainless panels complete with sill OR horizontally sliding collapsible accordion style car gate (various finishes available).

4.2.9 Safety Devices

The elevator will have the following safety devices:

4.2.9.1 208/230 VAC lockable disconnect for power unit

4.2.9.2 Final limit

4.2.9.3 Slack rope safety switch

- 4.2.9.4 Pit stop switch
- 4.2.9.5 Car top stop switch
- 4.2.9.6 Line rupture valve
- 4.2.9.7 Low pressure switch
- 4.2.9.8 Automatic releveling
- 4.2.9.9 Emergency battery lowering
- 4.2.9.10 Electromechanical door interlocks
- 4.2.9.11 Manual lowering device
- 4.2.9.12 Handrail inside cab
- 4.2.9.13 Emergency lighting in cab
- 4.2.9.14 Phone in cab

PART 5 – EXECUTION

5.1 Examination

All site dimensions and conditions shall be verified to ensure they meet specifications, codes and regulations.

5.2 Installation

Confirm that all site dimensions and conditions match those specified on shop drawings. Do not proceed with installation if the site dimensions and conditions are not acceptable. Elevator shall be installed by trained technicians in accordance with approved plans, specifications, manufacturer's installation instructions and local codes.

5.3 Maintenance

Elevator shall be maintained in accordance with the manufacturer's instructions and all applicable codes.

5.4 Warranty

Elevator shall carry a twenty-four (24) month limited warranty on parts only.